

Cat® Lift Trucks.

Your partner in materials handling.

DP70N						
Mast Type	h3	h1	h4	h2/h5	Tilt angle (fwd./back)	Q @ c = 600mm kg
	mm	mm	mm	mm		
Simplex	3060	2570	4277	200	6°/12°	7000
	3360	2720	4577	200	6°/12°	7000
	3560	2820	4777	200	6°/12°	7000
	3760	2920	4977	200	6°/12°	7000
	4060	3070	5277	200	6°/12°	7000
	4560	3320	5777	200	6°/12°	7000
	5060	3670	6277	200	6°/12°	7000
	5560	3920	6777	200	6°/6°	6700
	6060	4170	7277	200	6°/6°	6400
Triplex	4060	2470	5277	1253	6°/6°	6200
	4300	2570	5577	1353	6°/6°	6200
	4570	2640	5787	1423	6°/6°	6200
	4760	2720	5977	1503	6°/6°	6200
	5060	2820	6277	1603	6°/6°	6200
	5560	3070	6777	1853	6°/6°	6000
	6070	3240	7287	2023	6°/6°	5700

Mast Performance and Capacity

- h1 Height with mast lowered
- h2 Standard free lift
- h3 Lift height
- h4 Height with mast raised
- h5 Full free lift
- Q Lifting capacity, rated load
- c Load centre (distance)

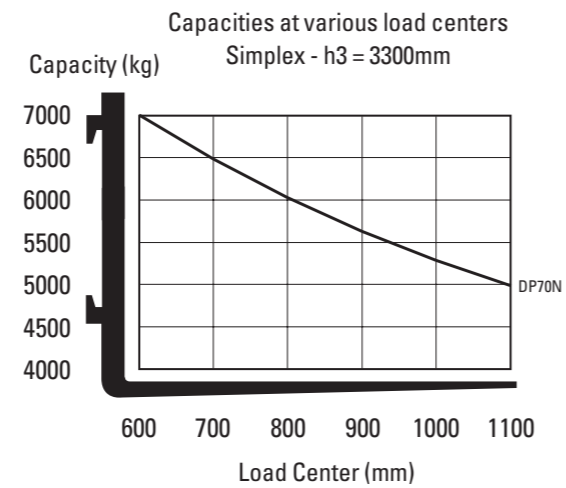

DP70N

Preliminary specifications

Engine powered lift trucks

7.0 tonnes

info@catliftruck.com
www.catliftruck.com

CEC1572(11/14)ok
©2014, MCFE. All rights reserved.
CAT, CATERPILLAR their respective logos,
'Caterpillar Yellow' and the 'Power Edge' trade dress,
as well as corporate and product identity used herein,
are trademarks of Caterpillar and may not be used
without permission.
Printed in The Netherlands

NOTE: Performance specifications may vary depending on standard manufacturing tolerances, vehicle condition, types of tyres, floor or surface conditions, applications, or operating environment. Trucks may be shown with non-standard options. Specific performance requirements and locally available configurations should be discussed with your Cat lift trucks Dealer. Cat Lift Trucks follows a policy of continual product improvement. For this reason, some materials, options and specifications could change without notice.



Characteristics			
1.1	Manufacturer (abbreviation)		Cat Lift Trucks
1.2	Manufacturer's model designation		DP70N
1.3	Power source: (battery, diesel, LP gas, petrol)		Diesel
1.4	Operator type: pedestrian, (operator)-standing, -seated		Seated
1.5	Load capacity	Q (kg)	7000
1.6	Load center distance	c (mm)	600
1.8	Load distance, axle to fork face	x (mm)	585
1.9	Wheelbase	y (mm)	2300
Weight			
2.1	Truck weight, without load / including battery (simplex mast, lowest lift height)	kg	9420
2.2	Axle loading with maximum load, front/rear (simplex mast, lowest lift height)	kg	14800/1620
2.3	Axle loading without load, front/rear (simplex mast, lowest lift height)	kg	4190/5230
Wheels, Drive Train			
3.1	Tyres: V=solid, L=pneumatic, SE=solid pneumatic - front/rear		L
3.2	Tyre dimensions, front		8.25X15-12PR
3.3	Tyre dimensions, rear		8.25X15-12PR
3.5	Number of wheels, front/rear (x=driven)		4X / 2
3.6	Track width (center of tyres), front	b10 (mm)	1650
3.7	Track width (center of tyres), rear	b11 (mm)	1650
Dimensions			
4.1	Mast tilt, forwards/backwards	α/β °	6/12
4.2	Height with mast lowered (see tables)	h1 (mm)	3060
4.3	Free lift (see tables)	h2 (mm)	200
4.4	Lift height (see tables)	h3 (mm)	3300
4.5	Overall height with mast raised	h4 (mm)	4277
4.7	Height to top of overhead guard	h6 (mm)	2610
4.8	Seat height	h7 (mm)	1592
4.12	Tow coupling height	h10 (mm)	485
4.19	Overall length	l1 (mm)	4800
4.20	Length to fork face (includes fork thickness)	l2 (mm)	3580
4.21	Overall width	b1/b2 (mm)	2170
4.22	Fork dimensions (thickness, width, length)	s, e, l (mm)	60/150/1220
4.23	Fork carriage to DIN 15 173 A/B/no		-
4.24	Fork carriage width	b3 (mm)	1600
4.31	Ground clearance under mast, with load	m1 (mm)	170
4.32	Ground clearance at center of wheelbase, with load (forks lowered)	m2 (mm)	263
4.33a	Working aisle width with 1000 x1200 mm pallets, crosswise	Ast (mm)	5095
4.34a	Working aisle width with 800 x1200 mm pallets, lengthwise	Ast (mm)	5295
4.35	Turning circle radius	Wa (mm)	3310
4.36	Minimum distance between centers of rotation	b13 (mm)	1260
Performance			
5.1	Travel speed, with/without load	km/h	22.5 / 26.5
5.2	Lifting speed, with/without load	m/s	0.47 / 0.49
5.3	Lowering speed, with/without load	m/s	0.50 / 0.50
5.5	Rated drawbar pull, with/without load	N	53000 / 27200
5.7	Gradeability, with/without load	%	35 / 27
5.10	Service brakes (mechanical/hydraulic/electric/pneumatic)		Hydraulic
IC Engine			
7.1	Manufacturer / Type		Perkins 854E
7.2	Rated output B to ISO 1585	kW	68
7.3	Rated speed to DIN 70 020	rpm	2300
7.4	Number of cylinders / cubic capacity	/cm ³	4 / 3400
7.5	Fuel consumption according to VDI 60 cycle	l/h / kg/h	-
Miscellaneous			
8.1	Type of drive control		Powershift 2/1
8.2	Maximum operating pressure for attachments	bar	191
8.3	Oil flow for attachments	l/min	-
8.4	Noise level, mean value at operator's ear	dB(A)	83.4
8.5	Towing coupling design / DIN type, ref.		Pin

* Fuel consumption data available on request



Ast = $Wa + x + l6 + a$
Ast = Working aisle width with load
a = Safety clearance (200 mm)
l6 = Pallet length (800 or 1000 mm)
b12 = Pallet width (1200 mm)

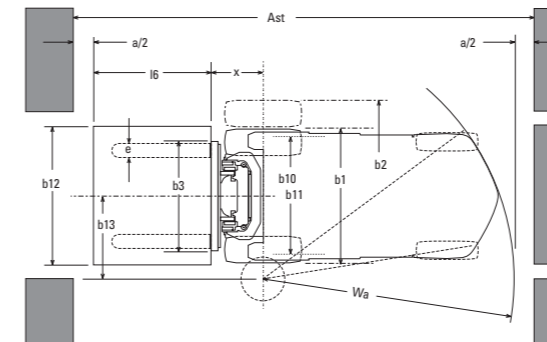
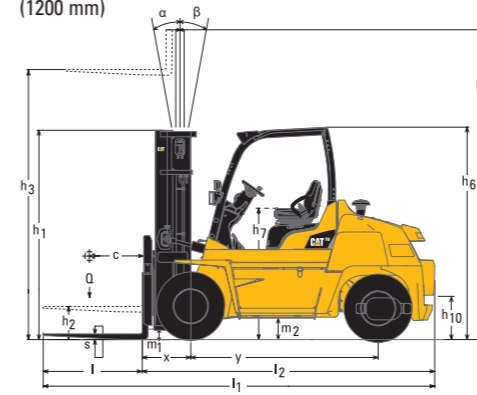

Lower Cost of Ownership

- Advanced Perkins 854E 4-cylinder diesel engine delivers powerful performance with 18% greater fuel efficiency than previous units and meets EURO Stage IIIB emissions standard.
- Low-maintenance Diesel Particulate Filter (DPF) technology with Passive Regeneration (PR) avoids the need for downtime by burning off soot while truck is operating.
- Engine Protection System (EPS) monitors oil pressure, coolant temperature and transmission temperature, giving warnings and limiting power output, travel speed and hydraulic speed if abnormalities are detected.
- Robust steel frame designed using Finite Element Analysis gives durable structure with low centre of gravity, resulting in higher residual capacity.
- Fully floating drive axle adds extra durability and capacity compared to semi- or non-floating alternatives.
- Steer axle construction as a single solid unit maximises strength and rigidity.
- Dependable engine and strong resistance of all truck components to damage and wear helps minimise repair and service bills.
- Easy and quick access to all areas for routine checks and maintenance keeps truck in sound working condition, saves time and reduces expense.

Unmatched Productivity

- Latest diesel engine design increases power to new levels.
- Powershift transmission offers two forward and two reverse gears to tackle every task effectively.
- Fast-response compact turbocharger further enhances driver experience and output.
- Design of frame and counterweight optimises weight positioning and residual capacity for strong lifting.

Safety and Ergonomics

- Noise and vibration limitation features include rubber-mounted key components, fully insulated steel engine hood and specially designed transmission gears.
- Fully hydrostatic assisted steering via small-diameter steering wheel ensures accurate and rapid response with little effort.
- Counterweight design allows small turning circle and clear view to the rear for precise manoeuvring.
- Mast with narrow channels and small-diameter lift cylinders increases forward vision and uses six load rollers with side rollers to achieve high load stability.
- Choice of up-to-date, ergonomic fingertip or lever controls is available for precise, low-effort operation of hydraulic functions.
- Comprehensively equipped instrument panel offers valuable on-the-go information and warnings to aid operator awareness and control.
- Presence Detection System (PDS) gives audible warning if seat belt is not fastened and prevents all travel and hydraulic movement if operator is not correctly seated.
- Vacuum-boosted hydraulic brakes increase braking efficiency and safety.
- Tiltable steering column, adjustable full-suspension seat and generous leg room allow each user to find the perfect driving position.
- Conveniently placed grab bars and steps ease access to operator compartment.

Options

- Engine Shutdown System (ESS) stopping engine in the event of:
 - Transmission temperature >110 °C
 - Coolant temperature >107 °C
 - Engine oil pressure <24 kPa
- Range of cabin options topped by fully enclosed version with air conditioning
- Wide range of sideshifters and fork positioners